



# ArgoCam®

Simple ~ Affordable ~ Underwater Video  
Delivered Straight to the Swimmers Phone  
Every Time They're Filmed



## FEATURES - BENEFITS - PROCESS

- Run a "Starter-Training-Filming Session" first
- We handle all scheduling and payment; give us a day and a lane
- While filming, we train your people how to use the ArgoCam
  
- Next Step: Lease the ArgoCam for a year as a Beta Tester
- Before delivery, we load your entire roster into the Argo app
- Every time a swimmer is filmed, they receive a text and email w/links
- Camera is carbon fiber, 3D printed, water-proof and shock-proof
- Use the huge Samsung S9 Ultra tablet independently ... underwater
- Use the huge Samsung S9 Ultra tablet at Swim Meets
- ArgoCam has two cameras; overwater and underwater
- Playback is instantaneous; includes slow motion and PIP screen
- Runs for 10 hours on a single charge; backup battery included
- SwimmerTrac® software keeps the swimmer in the frame
- Wireless bluetooth microphone allows recording while filming
- Private Coaches and Clinics; this is a game changer

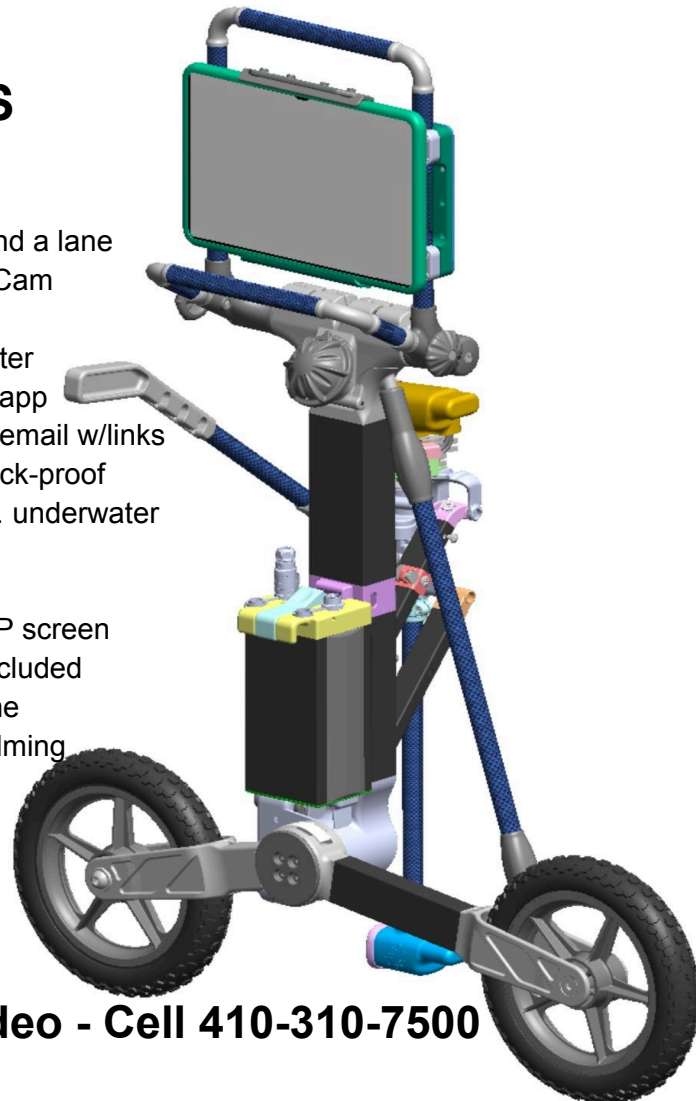

**Brad Hopkins - Argo Swim Video - Cell 410-310-7500**

## 1. **Argo Origin Story.**

My name is Brad Hopkins and I am the founder and CEO of Argo. I have spent 20 years filming 36,000 swimmers in 250 pools. Argo has now spent \$250,000 and three years of intense mechanical and electrical engineering creating this camera. Both hardware and software have been designed to effortlessly film thousands of swimmers, “solving for” acquisition, distribution and storage that’s so fast, easy and affordable that every team, big or small, slow or fast benefits from its use.

## 2. **First Visit to Your Pool.**

At this visit you look the camera over together and we film a few of your swimmers. You see and handle the camera asking lots of questions and getting hands-on answers to all of them. Including strategies to address the distribution of the cost of the camera lease, which is currently \$1000 per month for the first year. We also schedule a more structured filming session for a few weeks later; you pick the best day and time. We suggest a weekday practice. This makes it easy to get the filming done efficiently. Argo handles all scheduling and billing with a SignupGenius event software. You need only provide a date and an edge lane.

## 3. **Second Visit to Your Pool is a Filming Session.**

During this filming session we train one or two of your people in the use of the camera. Think “starter training”. You still need more time to get good at filming but this is a great running start on the process. We come and film the swimmers whose Parents have signed them up and paid. For this first filming we like to bring you a Samsung tablet. We use this tablet to capture and store all your video from this session. This enables you to keep the video in-hand using our app and teach with it. More importantly it sets the table for getting a camera. Cost of the Samsung S9 Ultra that we use is \$1200. This applies to the lease cost detailed below.

## 4. **Lease an ArgoCam for One Year as a Beta Tester.**

- a. \$5000 Security Deposit required which is only returned if you wish to terminate the lease
- b. Your camera build starts when we receive this check and it takes about a month
- c. On the day we deliver your new camera, your one-year lease begins.
- d. **A monthly payment of \$1000 for the entire first year is required.**
- e. After 5 months, you may return the camera for an unconditional refund of your \$5000 deposit.
- f. At the end of the first year, if you elect to keep the camera for another year, you get two free months as our way of saying thanks for being a Beta Tester.

## 5. **Third Visit ... Just Send It.**

We deliver the camera and train you to use it. Emphasis is on filming speed of over 100 swimmers per hour, using the **“Relay Filming Method” which is predicated on:**

- a. Eliminating the review of the video with the swimmer ... just send it to their phone.
- b. Lining them up on both ends and filming them **for no more than 25 yards in 30 seconds or less**
- c. **Focusing on one issue only ...** ex Fly Kick or Backstroke Head Position or Freestyle Hand Entry
- d. Capping the filming at 25 yards which enables you to get two swimmers done per minute

## 6. **Figuring Out Your Use-Case.**

**This takes no less than five months.** Once you have your camera you can get busy filming your swimmers, daily, weekly or monthly.. Using the Relay Filming techniques, you’ll be able to film over a hundred swimmers per hour. You now have the ability to fulfill your monthly filming requirements in a matter of hours. Again, there is no “coaching” associated with the video that is delivered to the swimmers’ phone ... Just send it. Over and over and over again. **It is only through relentless repetition that the power and value of this camera can be realized.** Which is why the “Relay Filming Method” is so crucial. Get filming done fast and frequently. In small bites. This is how kids learn.